

Hex-Cor Augers - 13/16 Hex Connector 1125 Series

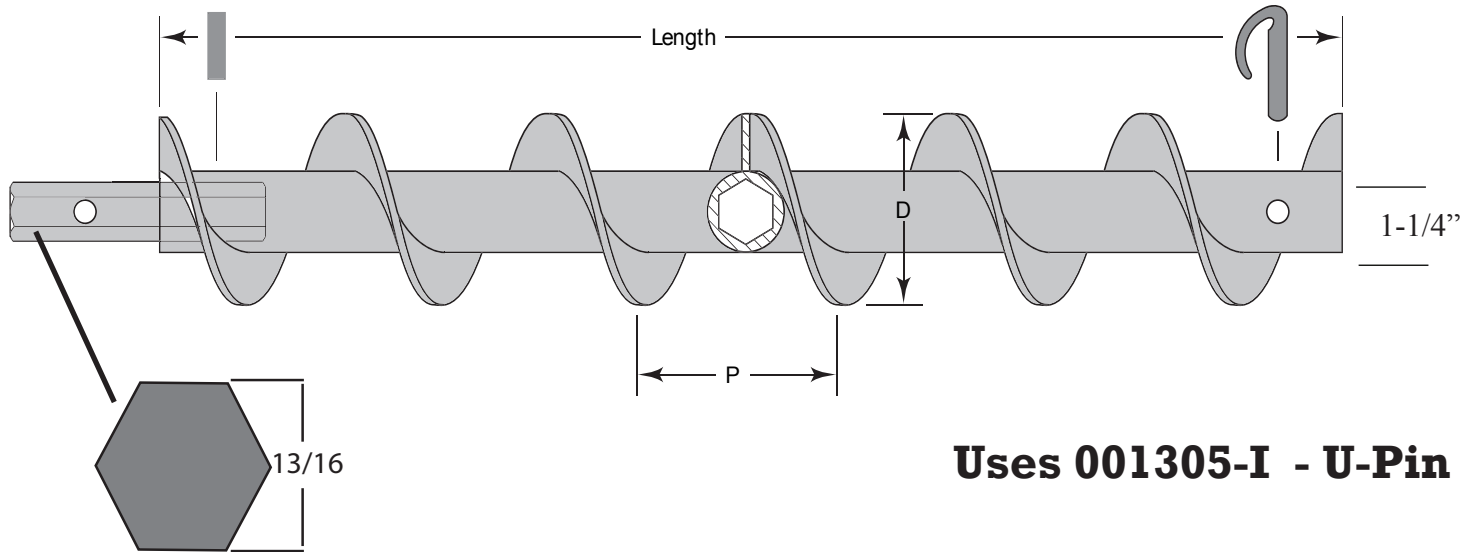

Uses 001305-I - U-Pin

Repair Hex Shank - 003997

Tubing - AISI 4130 Cold Drawn, Stress Relief Annealed, Steel Tubing
Hex Shank - Cold Drawn AISI 4140 13/16", Heat Treated
Flight - Hot Rolled Flat AISI 1020 Steel-Thickness 1/4"
Retaining Pin - AISI 4140 Steel, Heat Treated to 43-48 Rockwell.

Available in Hole Sizes 2-1/2" through 3"

- Field replacement shank
- Internal hex tubing
- Hardfaced flight edges

Groove Pin



150279

Augers are identified by hole size not actual size.

Hole Size		"D" Diameter		"P" Pitch		Hex Conn.		Stock Length		Weight		Part #
in	mm	in	mm	in		in	m	ft	m	lbs.	kg.	
2-1/2	64	2-3/8	60	2	51	13/16	21	3	.91	12	5.4	001165
								5	1.5	18	8.2	001167
3	76	2-5/8	67	2	51	13/16	21	3	.91	14	6.4	001168
								5	1.5	22	10.0	001170

Hex-Cor Augers - 1-1/8 Hex Connector

1500 Series

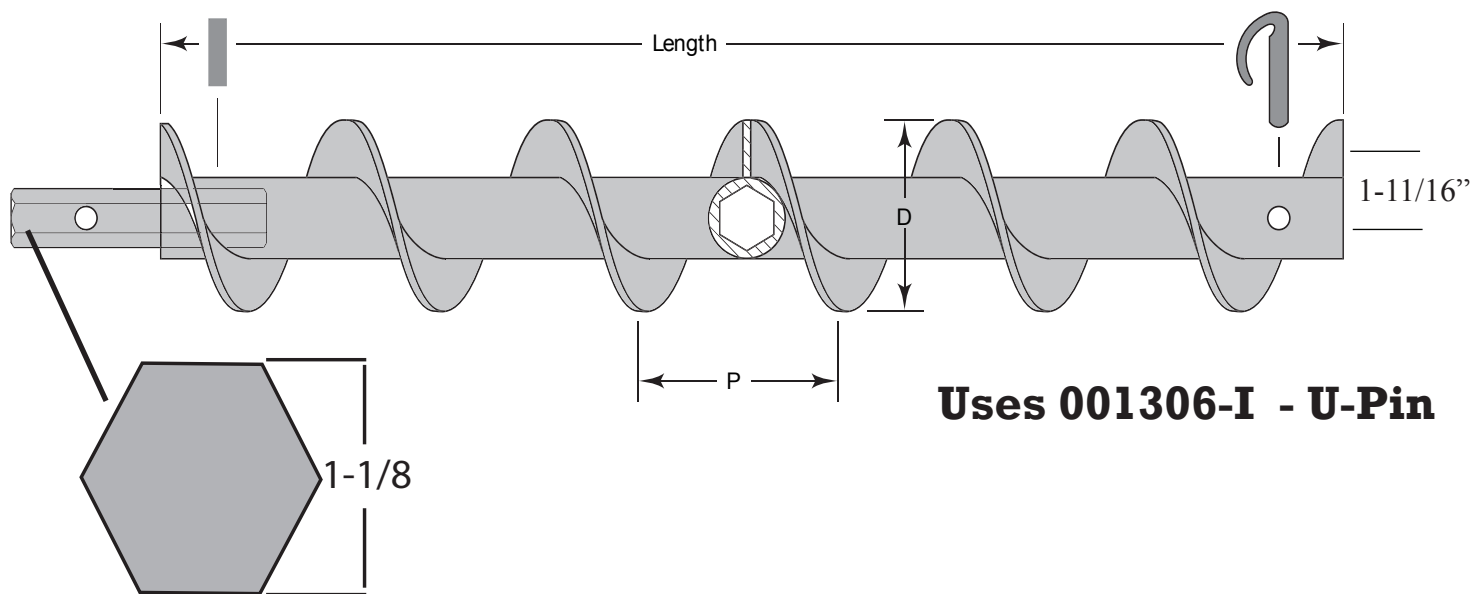

Repair Hex Shank - 003996-I

Tubing - AISI 4130 Cold Drawn, Stress Relief Annealed, Steel Tubing

Hex Shank - Cold Drawn AISI 4140 1-1/8", Heat Treated

Flight - Hot Rolled Flat AISI 1020 Steel-Thickness 1/4"

Retaining Pin - AISI 4140 Steel, Heat Treated to 43-48 Rockwell.

Groove Pin

Available in Hole Sizes 3-1/2" through 6"

- Field replacement shank
- Internal hex tubing
- Hardfaced flight edges

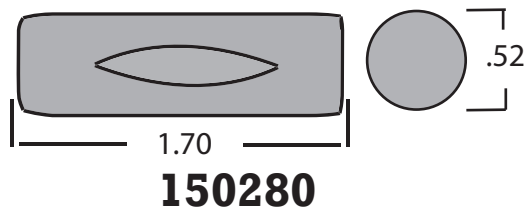

Augers are identified by hole size not actual size.

Hole Size		"D" Diameter		"P" Pitch		Hex Conn.		Stock Length		Weight		Part #
in	mm	in	mm	in	mm	in	m	in	m	lbs.	kg.	
3-1/2	89	3-1/4	83	3-1/3	85	1-1/8	29	3	.91	18	8.2	001171
								5	1.5	30	13.6	001173
4-1/2	114	4	102	3-1/3	85	1-1/8	29	3	.91	22	10.0	001174
								5	1.5	34	15.4	001176
								10	3.1	70	31.8	004812
5	127	4-1/2	114	4	102	1-1/8	29	3	.91	27	12.2	001177
								5	1.5	36	16.3	001179
6	152	5-1/2	140	5	127	1-1/8	29	3	.91	26	11.8	001180
								5	1.5	40	18.1	001182

Hex-Cor Augers - 1-5/8 Hex Connector

2000 Series

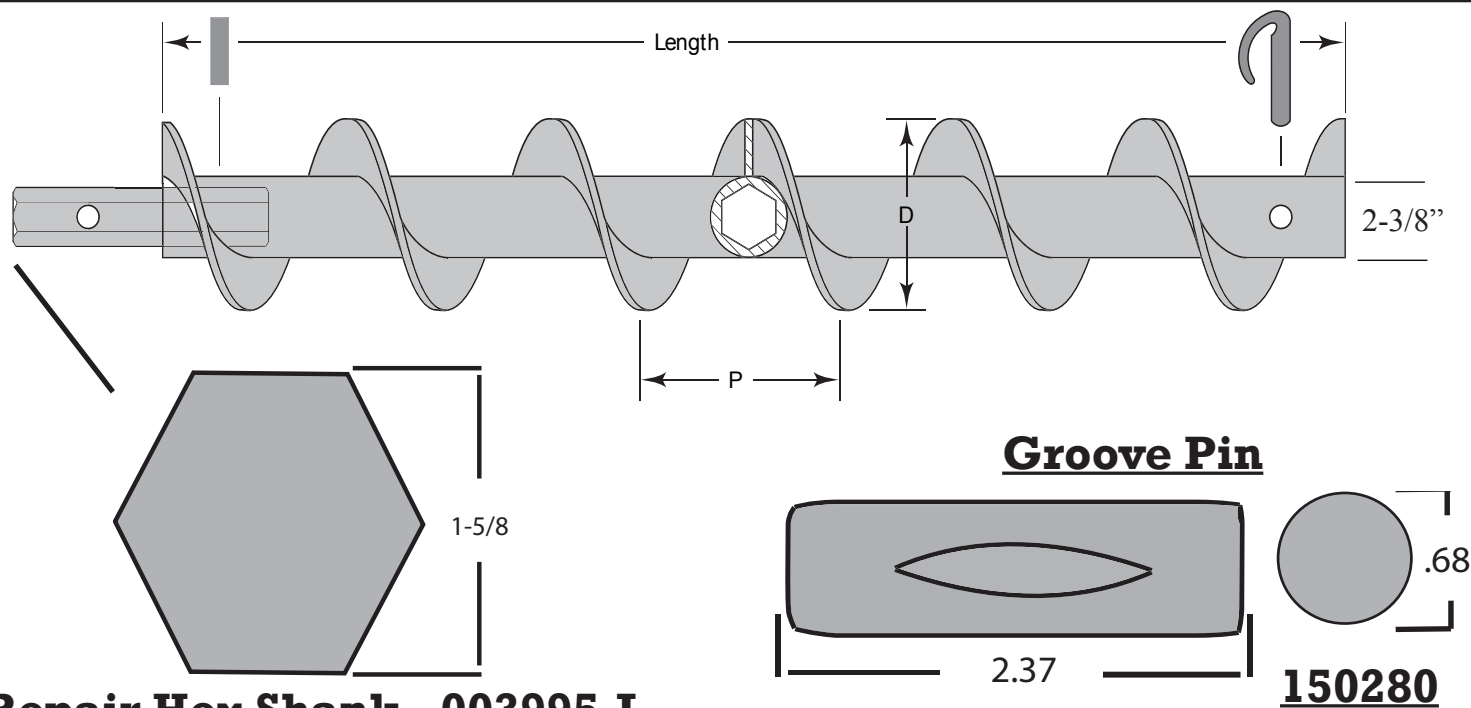

Repair Hex Shank - 003995-I

Tubing - AISI 4130 Cold Drawn, Stress Relief Annealed, Steel Tubing

Hex Shank - Cold Drawn AISI 4140 1-5/8", Heat Treated

Flight - Hot Rolled Flat AISI 1020 Steel-Thickness 1/4" or 3/8"

Retaining Pin - AISI 4140 Steel, Heat Treated to 43-48 Rockwell.

Available in Hole Sizes 4-1/2" through 12"

Uses 001307-I - U-Pin

- Field replacement shank
- Internal hex tubing
- Hardfaced flight edges

 = most popular

Augers are identified by hole size not actual size.

Hole Size		"D" Diameter		"P" Pitch		Hex Conn.		Stock Length		Weight		Part #
in	mm	in	mm	in	mm	in	m	in	m	lbs.	kg.	
4-1/2	114	4	102	3-1/3	85	1-5/8	41	3	.91	22	10	007208
								5	1.5	54	24.5	001185
								10	3.0	104	47.2	001186
5	127	4-1/2	114	4	102	1-5/8	41	5	1.5	54	24.5	001189
								10	3.0	106	48.1	001190
6	152	5-1/2	140	5	127	1-5/8	41	5	1.5	58	26.3	001191
								10	3.0	115	50.3	001192
7	178	6	152	5	127	1-5/8	41	5	1.5	64	29.0	001193
8	203	7	178	7	178	1-5/8	41	5	1.5	72	32.7	001195
								10	3.0	139	63.0	001196
10	254	8-7/8	225	7	178	1-5/8	41	5	1.5			007240
12	305	10	254	8	203	1-5/8	41	5	1.5			007241

Continuous Flight Augers - 1-5/8 Hex

2000 Series

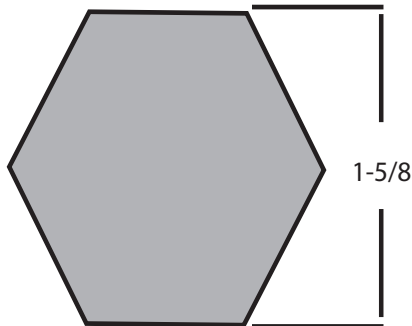
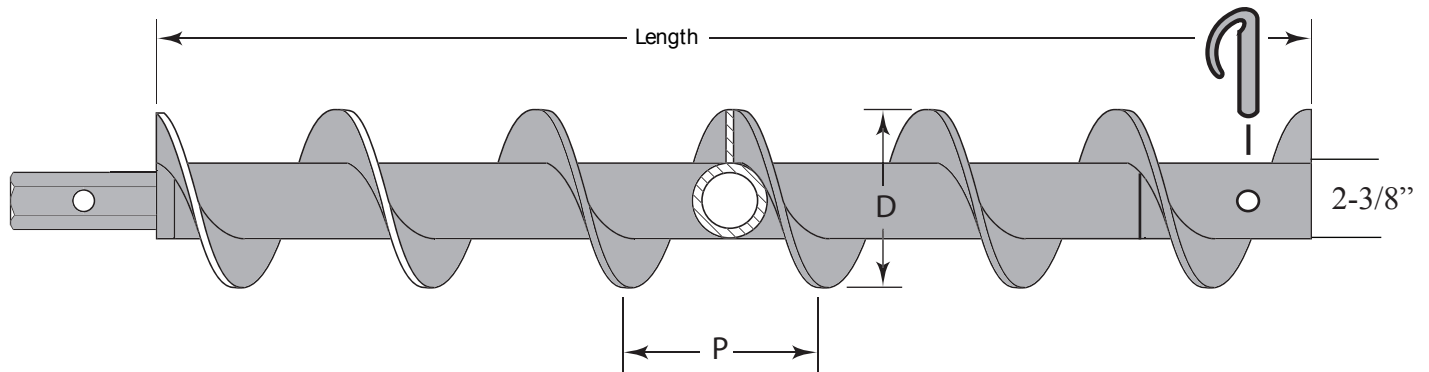

Repair Hex Shank - 150113-I
Repair Hex Socket - 150324

Uses 001307-I - U-Pin

Available in Hole Sizes 4-1/2" through 14".

- Hex shank & socket connector are welded to the auger
- Sizes are identified by the hole size, not actual flight diameter

Please note actual flight diameter is less than hole diameter.

Augers are identified by hole size not actual size.

Hole Size		"D" Diameter		"P" Pitch		Hex Conn.		Stock Length		Weight		Part #
in	mm	in	mm	in	mm	in	m	ft	m	lbs.	kg.	
4-1/2	114	4	102	3-1/3	85	1-5/8	41	5	1.5	42	19.1	004360
								10	3.0			004361
5	127	4-1/2	114	4	102	1-5/8	41	5	1.5	44	20.0	004364
6	152	5-1/2	140	5	127	1-5/8	41	5	1.5	48	21.8	004366
								10	3.0			004367
7	178	6	152	5	127	1-5/8	41	5	1.5	54	24.5	004368
8	203	7	178	7	178	1-5/8	41	3	.91			150254-03
								5	1.5	60	27.2	004370

Continuous Flight Augers - 1-5/8 Hex

2875 Series

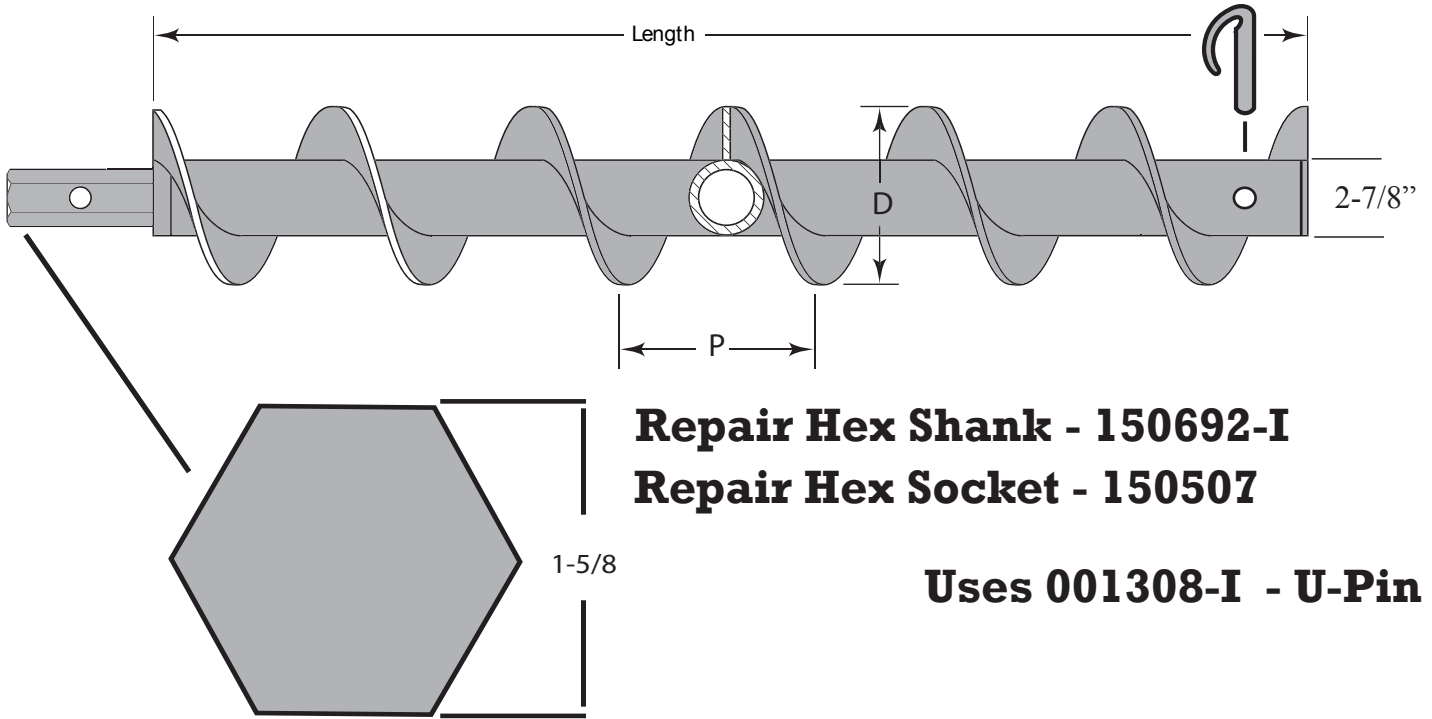

Available in Hole Sizes 10" through 12".

- Hex shank & socket connector are welded to the auger
- Sizes are identified by the hole size, not actual flight diameter

Please note actual flight diameter is less than hole diameter.

Augers are identified by hole size not actual size.

Hole Size		"D" Diameter		"P" Pitch		Hex Conn.		Stock Length		Weight		Part #
in	mm	in	mm	in	mm	in	m	ft	m	lbs.	kg.	
10	254	8-7/8	225	8	203	1-5/8	41	5	1.5	90	40.8	004374
								10	3.0	127	57.6	004375
12	305	10	254	9	229	1-5/8	41	5	1.5	102	46.3	004376
								10	3.0	135	61.2	004377

Continuous Flight Augers - 2" Hex

2625 Series

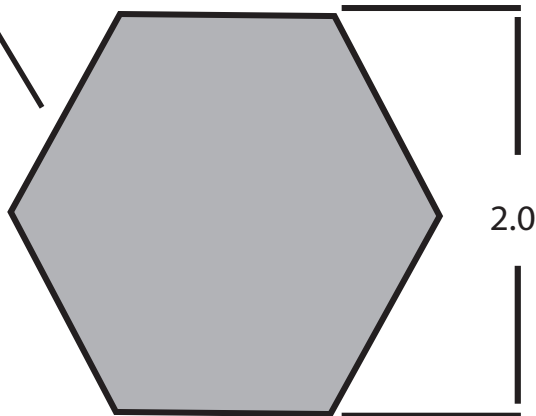
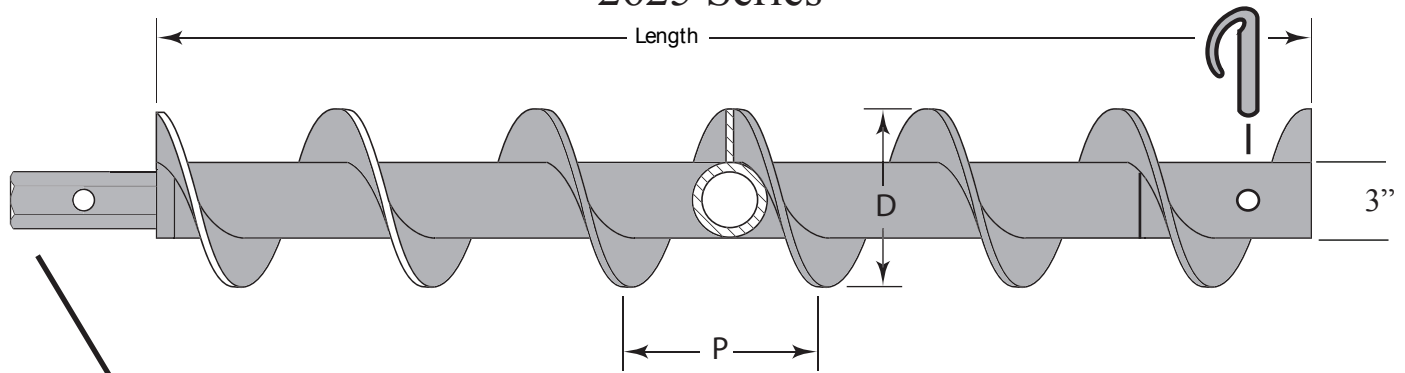

Repair Hex Shank - 005646-I
Repair Hex Socket - 003478-01

Available in Hole Sizes 6" through 14"

Uses 001308-I - U-Pin

- Hex shank & socket connector are welded to the auger
- Sizes are identified by the hole size, not actual flight diameter

Please note actual flight diameter is less than hole diameter.

Hole Size		"D" Diameter		"P" Pitch		Hex Conn.		Stock Length		Weight		Part #
in	mm	in	mm	in	mm	in	m	ft	m	lbs.	kg.	
6	152	5-1/2	140	5	127	2	51	5	1.5	68	30.8	003472
8	203	7	178	7	170	2	51	5	1.5	74	33.6	003474
10	254	8-7/8	225	8	203	2	51	5	1.5	104	47.2	003475
12	305	10	254	8	203	2	51	5	1.5	112	55.3	003476
14	356	12	305	9	229	2	51	5	1.5	139	63.1	004975

Larger diameter available on request

U-Pins

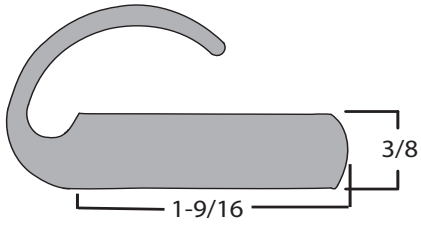

001305-I

1500 Series

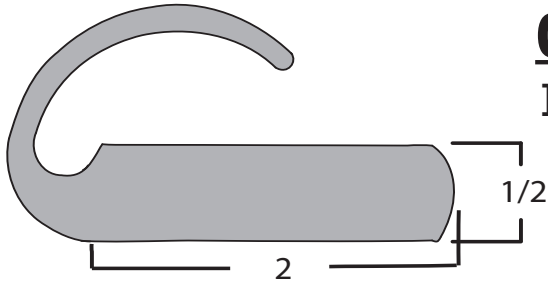

001306-I

1500 Series

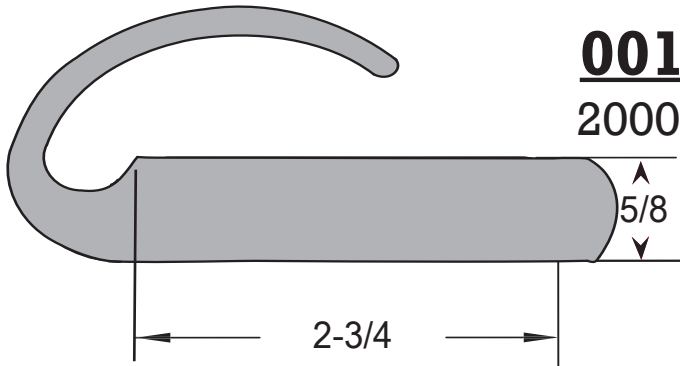

001307-I

2000 Series

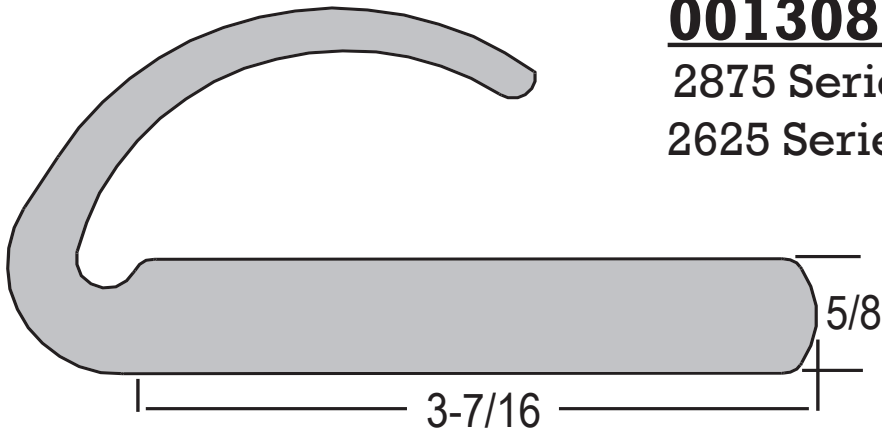

001308-I

2875 Series

2625 Series

Description	lbs.	Part No.
13/16 Hex	.10	001305-I
1-1/8 Hex	.19	001306-I
1-5/8 Hex	.35	001307-I
1-5/8, 2 Hex	.46	001308-I

Hex Shank



Size	Part No.	Hex Shank
6"	6SB-3W-158H	1 - 5/8"
8"	8SB-3W-158H	1 - 5/8"

Dirt Pilot Bits

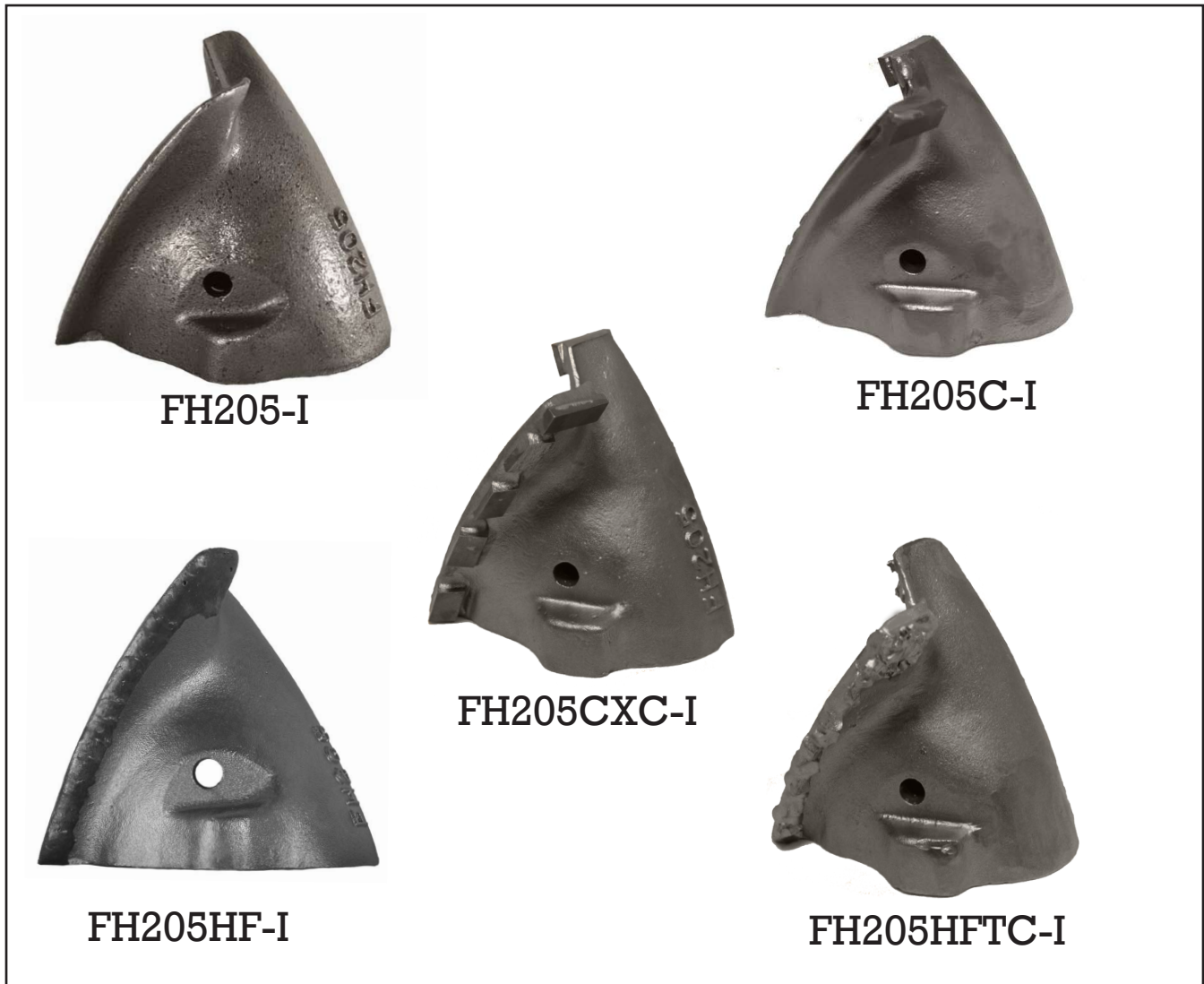

Part No.	Application	Description	Unit lbs.
FH205-I	Ordinary Dirt	Standard	3.0
FH205C-I	Rock/Abrasive Soil	Carbide Tipped	3.0
FH205HF-I	Abrasive Soil- High Impact	Hardfaced	3.0
FH205CXC-I	Compacted Rock	Carbide Edges	3.0
FH205HFTC-I	Abrasive Soil- Low Impact	Chunky Carbide	3.0

SB Dirt Pilot Bits



Standard



Carbide Tip-C



Hard Faced-HF



Carbide Edge-CXC



Hard Faced Tungston Carbide
HFTC

DrillingWorld SB Pilot Bits are available to upgrade for your any of your drilling needs.

Part No.	Diameter	Lug Size	Unit lbs.
SB25-I	2 1/2"	Small	0.8
SB30-I	3"	Small	1.0
SB35-I	3 1/2"	Med.	2.0
SB45-I	4 1/2"	Med.	3.0
SB50-I	5"	Large	3.0
SB60-I	6"	Large	4.0
SB70-I	7"	Large	4.0
SB80-I	8"	Large	5.0
SB90-I	9"	Large	5.0
SB100-I	10"	Large	7.0
SB120-I	12"	Large	7.0

Drive Lugs - Fitment Guide

Large Drive Lug
Fits SB50 to SB120

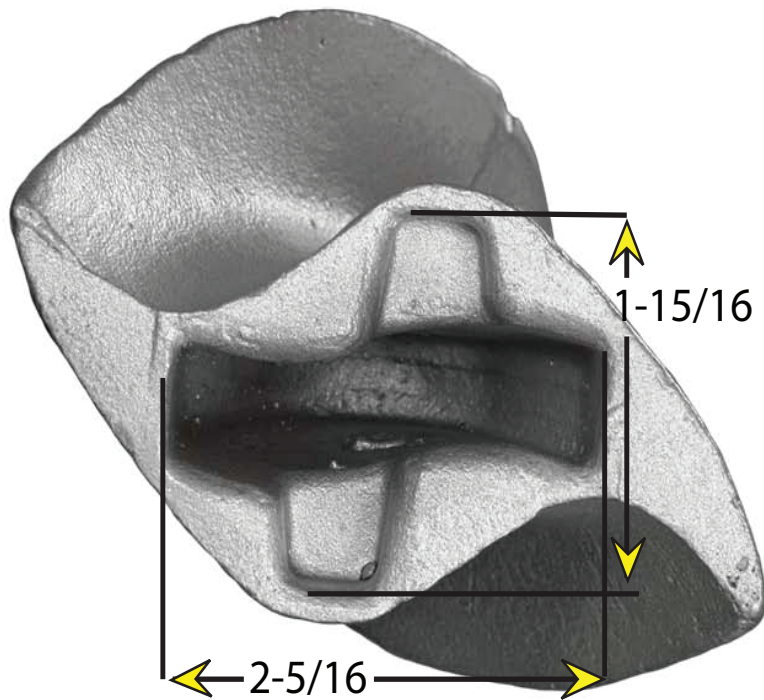
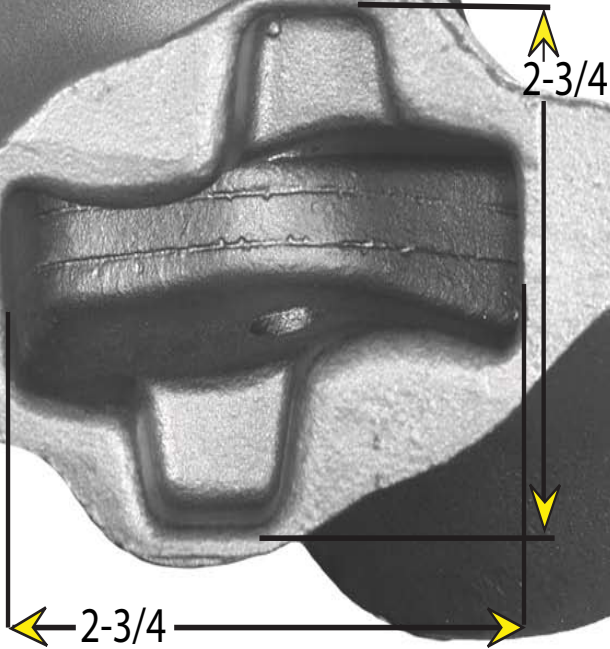

Medium Drive Lug
Fits SB35 to SB45

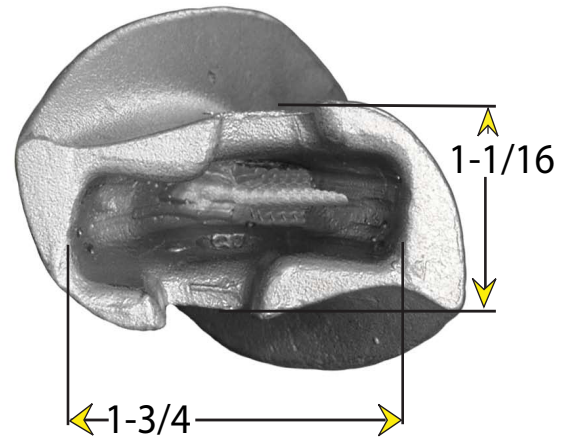

Small Drive Lug
Fits SB25 & SB30

Drive Lugs - Large

MHX141L-I

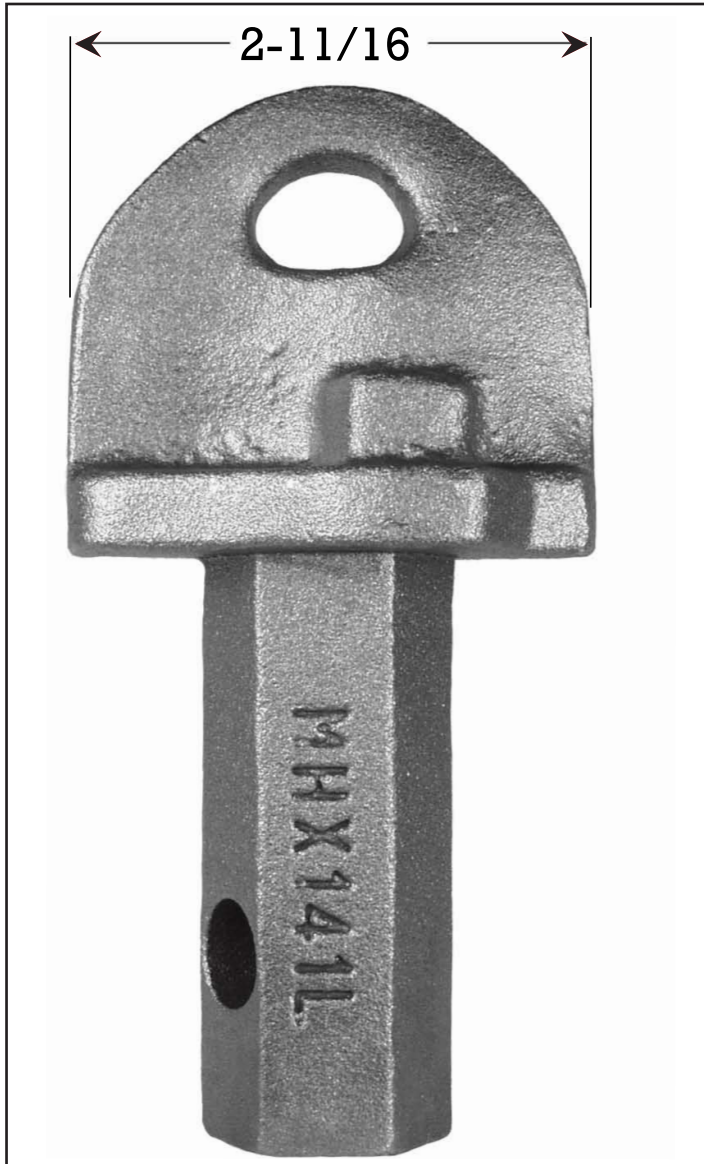

LHX141L-I

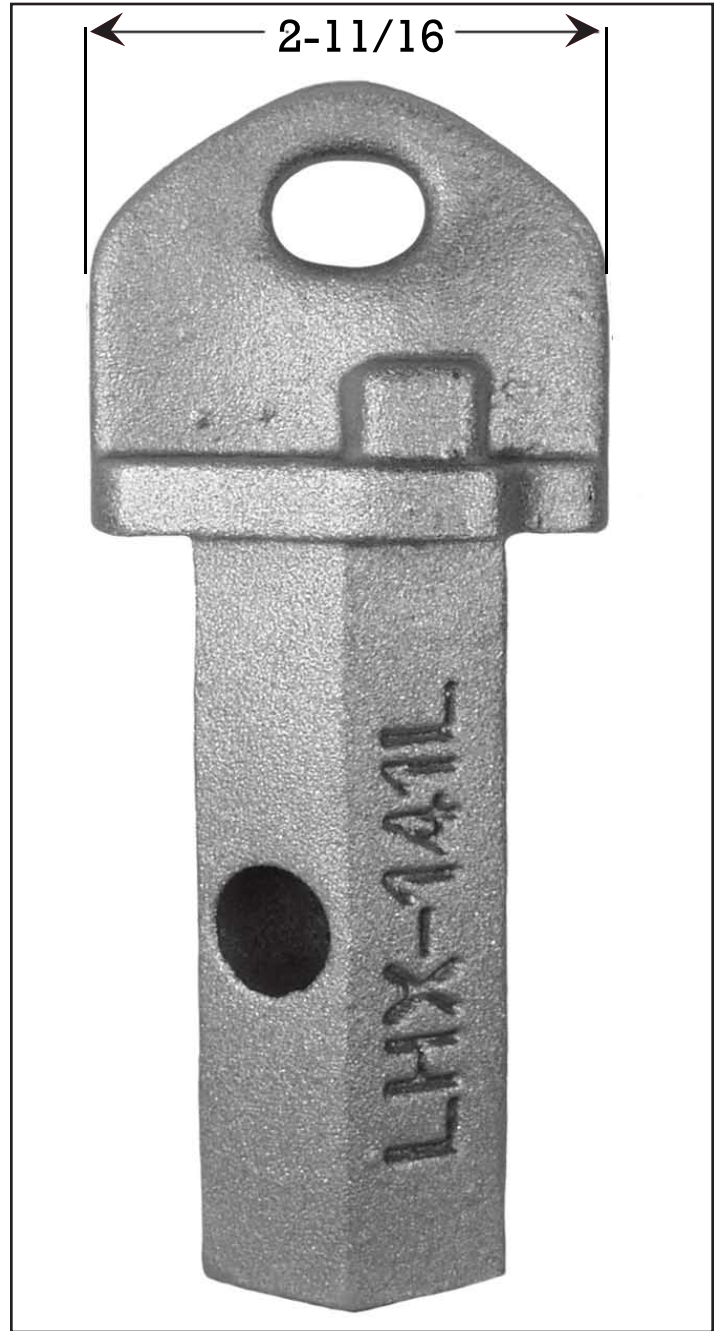

141L-I



Description	Shank Connector	Approx. WT.	Used On
MHX141L-I	1-1/8 hex	2.3	SB50 to SB120
LHX141L-I	1-5/8 hex	3.8	
141L-I	Weld-On	1.8	

Drive Lugs - Med

MHX141M-I

LHX141M-I

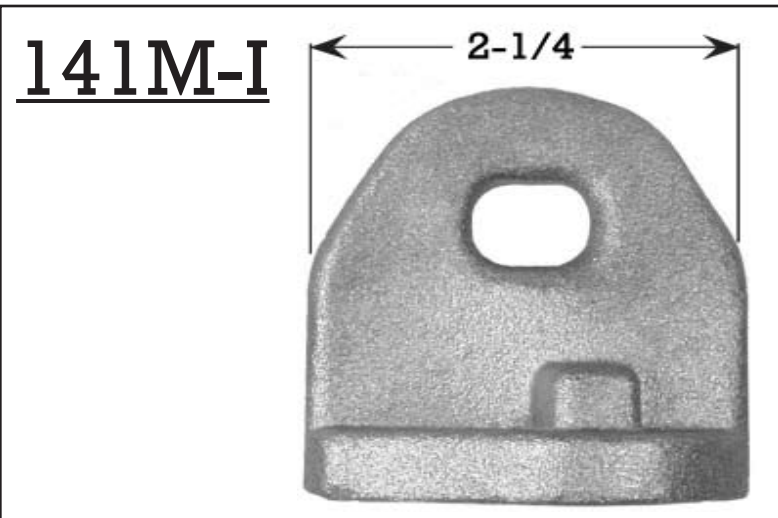
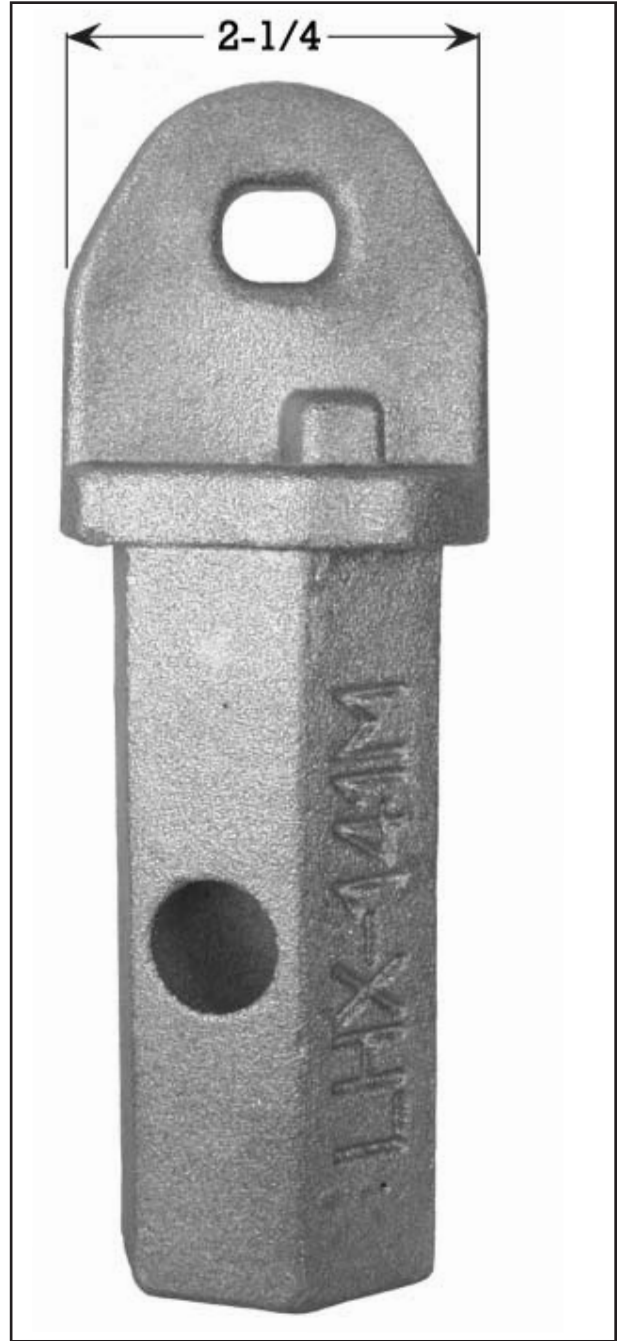
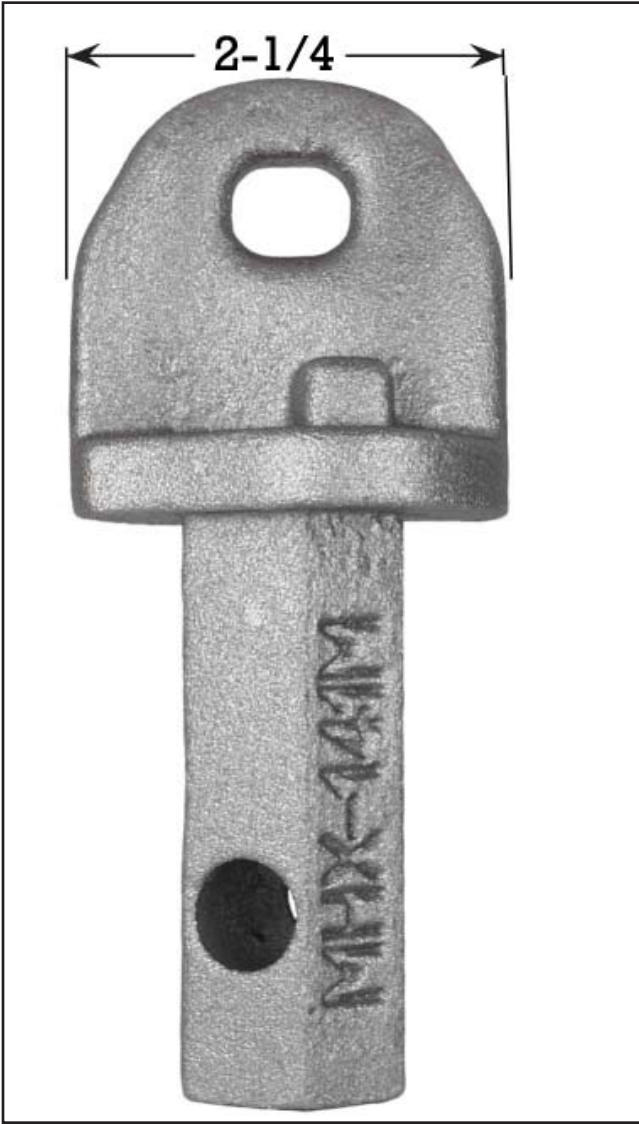

Description	Shank Connetor	Approx. WT.	Used On
MHX141M-I	1-1/8 hex	1.6	SB35 or SB45
LHX141M-I	1-5/8 hex	3.1	
141M-I	Weld-On	1.0	

Drive Lugs - Small

SHX140S-I

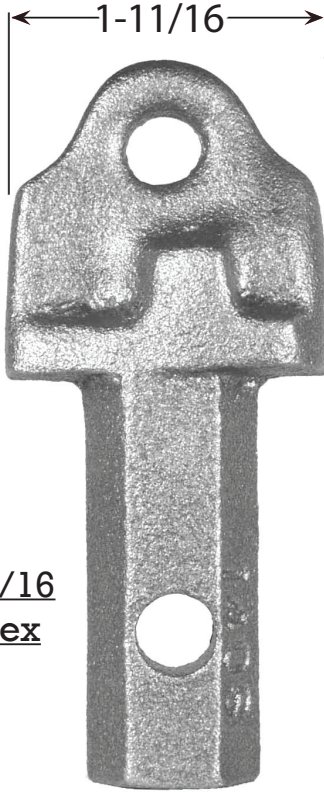

MHX140S-I



140CS-I



140S-I

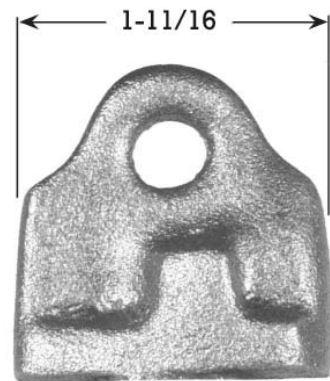

Description	Shank Connector	Approx. WT.	Used On
SHX140S-I	13/16 hex	0.6	SB25 or SB30
MHX140S-I	1-1/8 hex	1.0	
140S-I	Weld-On	0.4	
140CS-I	Weld-On	0.9	

Continuous Flight Augers Cutterhead

DP Cutterhead

The DP Drill Head with DP bits, is a 3-wing, prop-type drill head that can increase auger drilling rates by 50% or more in soft or medium formations.

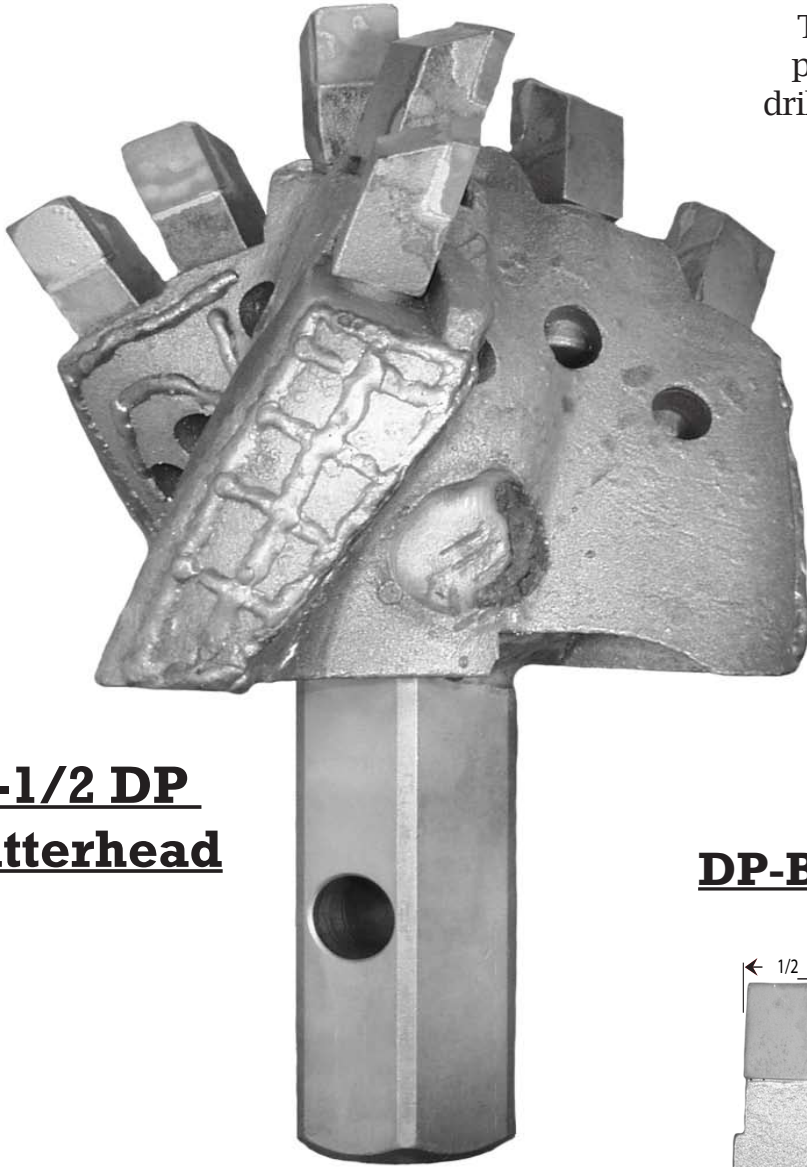

**6-1/2 DP
Cutterhead**

Hole Size		Part #
in.	mm.	
4 1/2"	114	DP4-I
6 1/2"	164	DP6-I
9"	240	DP8-I
11"	278	DP10-I
12 1/2"	316	DP12-I
DP Bit		DP-BIT-I
Heavy Duty Bit		DPHD-BIT-I
Claw Bit		DPC-BIT-I
Tooth Removal Tool		DPP-I

DP-Bit-I DPC-Bit-I DPHD-Bit-I

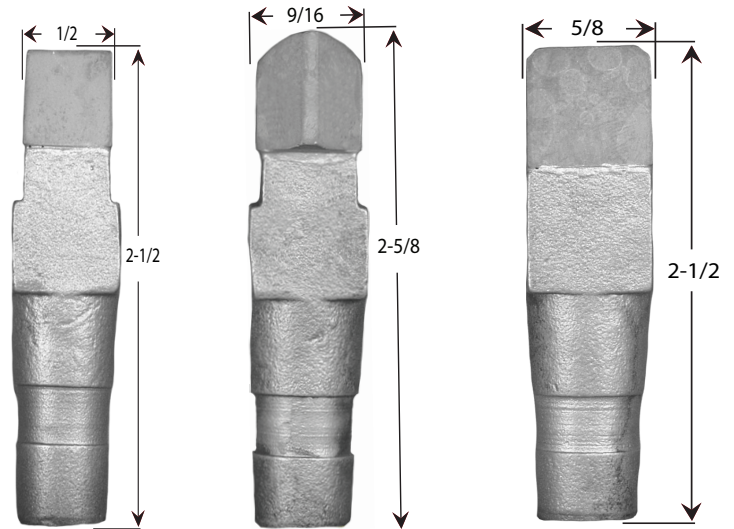

DPP-Punch



Continuous Flight Augers Cutterhead

5T Cutterhead



4-1/2 5T Cutterhead

Sands, Silts, Shale & Fracturable Rock.
5T Cutter heads use replaceable carbide
tipped teeth. Cutter heads come standard
Hard Faced for longer life

Hole Size		Part #	Hex Connection		Bits Per Head
in.	mm.		in.	mm.	
3 1/8	80	19002-I	13/16	21	2
3 1/8	80	19003-I	1 1/8	29	2
4 1/2	114	19004-I	1 1/8	29	4
4 1/2	114	19005-I	1 5/8	41	4
5	127	19006-I	1 1/8	29	4
5	127	19007-I	1 5/8	41	4
6	152	19008-I	1 1/8	29	4
6	152	19009-I	1 5/8	41	6
6 3/4	171	19009-I	1 5/8	41	6
		5T-I	Replacement 5T Bits		
		5TCB-I	Replacement 5T Claw Bit		
		5T-S-I	Replacement 5T Short Bit		

Continuous Flight Augers Cutterhead

5T Bits

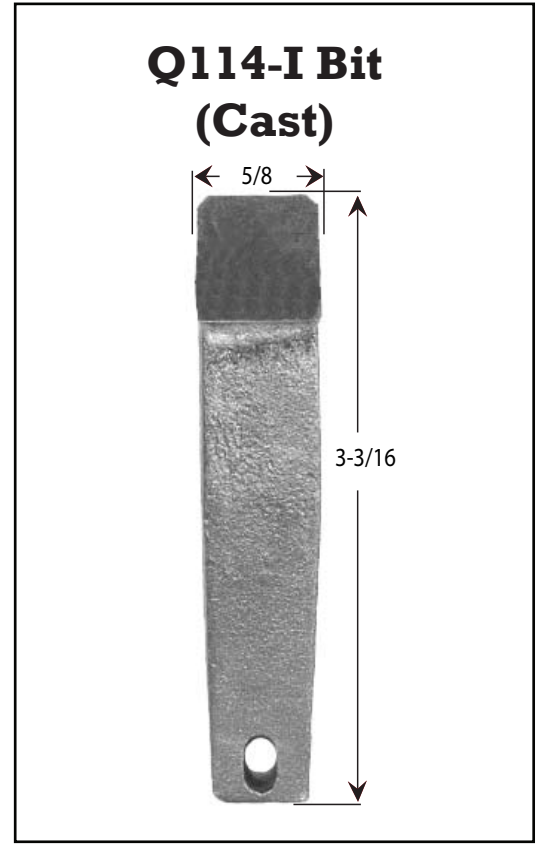
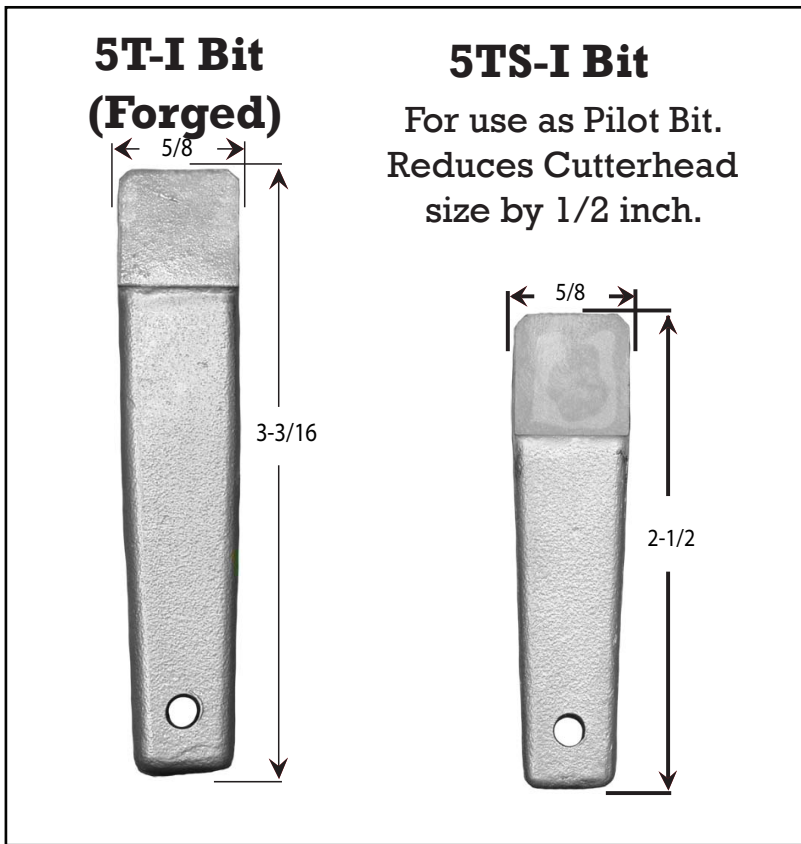

5T Claw Bit

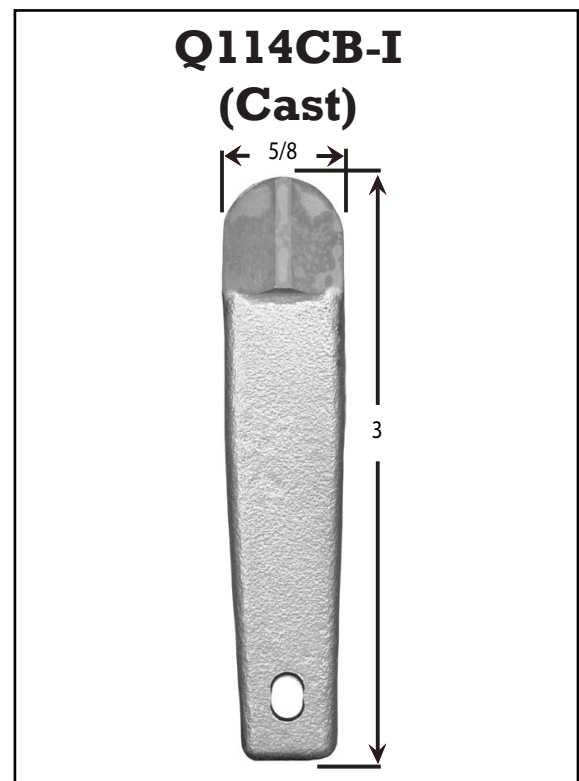
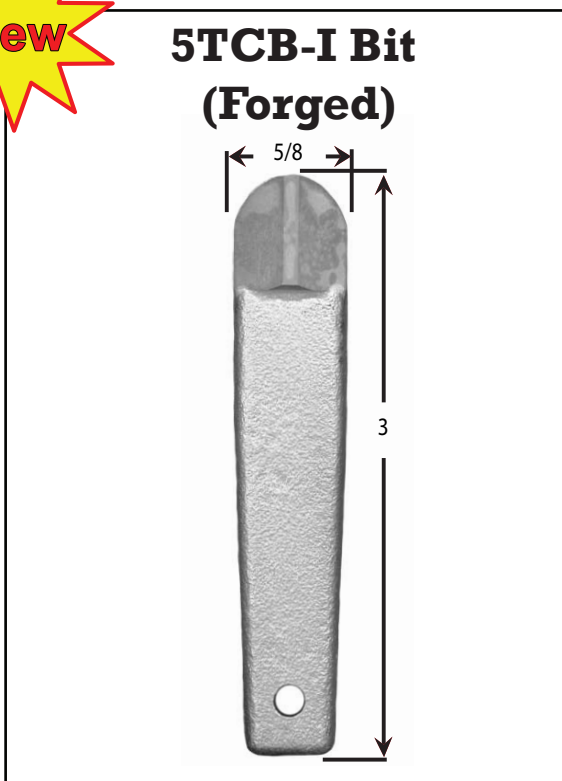

Continuous Flight Augers Cutterhead

Bulldog Cutterhead



**4-1/2 Bulldog
Cutterhead**

**150233
Bit**

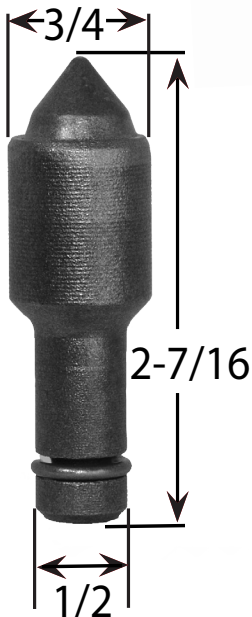

Tough, multi-purpose auger head for full range drilling. Uses replaceable cone-shaped carbide insert bits depending upon the formation requirements. Bits are designed to revolve during the cutting action for a more uniform wear pattern and longer service life.

Hole Size	Part #	Hex Connection		Weight		# of bits per head	
		in.	mm.	lb	kg		
4-1/2	61017-04	1-1/8	29	9	4.0	6	
4-1/2	61017-14	1-5/8	41	10	4.5	6	
6	61017-06	1-1/8	29	13.5	6.1	8	
6	61017-16	1-5/8	41	16	7.3	8	
6	61017-25	2	51	20.0	9.1	8	
	150233	Bulldog Bit, Carbide Insert					

Continuous Flight Augers Cutterhead

Multi-Purpose Cutter Head



Tough, multi-purpose auger head for full range drilling. Uses replaceable carbide insert bits depending of the formation encountered. Bits are held in place by malleable iron bit wedges.

006002- Carbide Bit

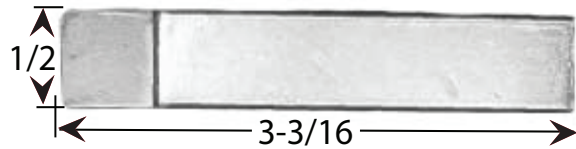

006000- Hard Faced Bit



Hole Size		Carbide Part #	Hard Faced Part #	Hex Connection		# of bits per head
in.	mm.			in.	mm.	
4-1/2	114	001536-01	001536	1-1/8	29	4
5	127	006959-01	006959	1-1/8	29	6
6	152	001540-01	001540	1-1/8	29	8
4-1/2	114	001538-01	001538	1-5/8	41	4
5	127	006960-01	006960	1-5/8	41	6
6	152	001543-01	001543	1-5/8	41	8
7	178	001544-01	001544	1-5/8	41	8
8	203	001545-01	001545	1-5/8	41	10
10	254	001547-01	001547	1-5/8	41	12
12	305	001548-01	001548	1-5/8	41	14
6	152	003480-01	003480	2	51	8
8	203	003482-01	003482	2	51	10
10	254	003483-01	003483	2	51	12
12	305	003484-01	003484	2	51	14
			006002	Replacement Carbide Bits		
			006000	Replacement Hard Faced Bits		

Continuous Flight Augers Cutterhead

Multi-Purpose Cutter Head Wedges

33-I

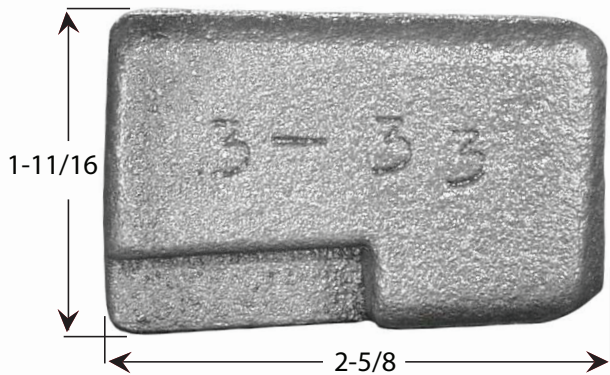

37-I

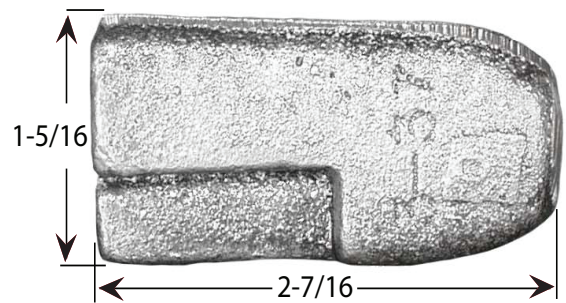

34-I

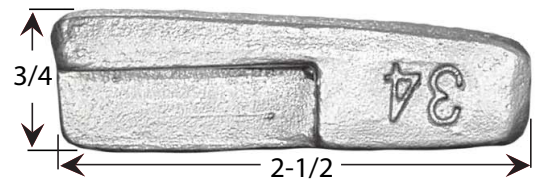

Part #	Description	Fits Head	Wt. lbs.
33-I	Double Wedge Wide	4-1/2"	.32
37-I	Double Wedge Narrow	5" - 12"	.72
34-I	Single Wedge	5", 8", 12"	.23

Number of Wedges Required

Head Diameter	Wedge 33-I Qty.	Wedge 37-I Qty.	Wedge 34-I Qty.
4-1/2"	2	0	0
5"	0	2	2
6"	0	4	0
7"	0	4	0
8"	0	4	2
10"	0	6	0
12"	0	6	2